

PRORIL

50Hz

GOVOX-U Series, these vortex pumps feature a less impeller wear and longer pump life by a vortex flow that allows fibrous materials and solid matters to be pumped out without obstruction.

Sewage Pump

GOVOX-U 455/475

Vortex Pump



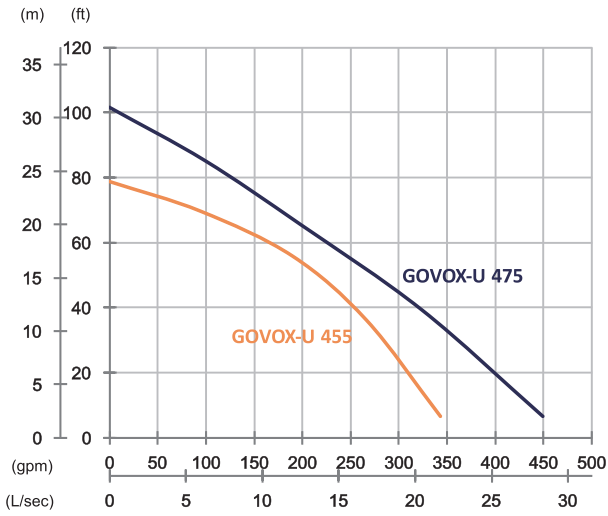

	GOVOX-U 455	GOVOX-U 475
OUTPUT	5.5 kW (7.5 HP)	7.5 kW (10 HP)
OUTLET	4" (100 mm)	4" (100 mm)
SOLID PASSAGE	55 mm	55 mm
Weight	60 kg	67 kg
HEAD	Rated: 17 m Max: 24 m	Rated: 20 m Max: 31 m
FLOW	Rated: 12 L/s Max: 21.7L/s	Rated: 12.5 L/s Max: 28.3 L/s

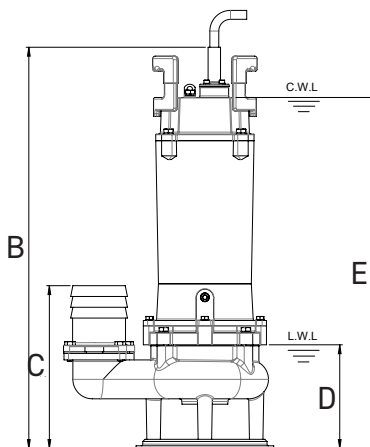
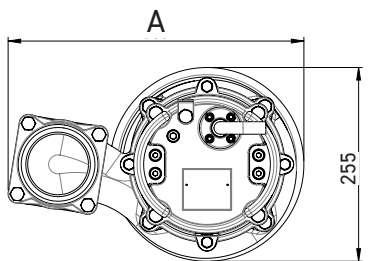

	A	B	C	D	E
GOVOX-U 455	376	722	295	159	618
GOVOX-U 475	389	756	302	192	652

unit : mm
C.W.L : Continuous running water level
L.W.L : Lowest running water level

Pump Type		Electric Submersible Pumps
Motor	Phase	3-Phase
	Type	Induction Motor
	Poles	2 Pole (2850 rpm)
	Insulation	Class F
	Protector	Circle Thermal Protector
	Starter	D.O.L.
Lubricant		Food Grade (ISO VG32)
Specs.	Impeller Type	Vortex
	Shaft Seal	Double Mechanical Seal
		Silicon Carbide VS Ceramic/Carbon
	Bearings	C3 Shielded ball bearings
	Cable	H07RN-F
10 m or longer upon request		
Materials	Pump Casing	Ductile Iron
	Impeller	Gray Iron
	Motor Frame	Gray Iron
	Motor Shaft	Stainless Steel
Max. Liquid Temperature		40°C (104°F)
Max. Submersion Depth		20 m (66 ft)
pH Range		pH 5 - pH 8